

# NeverFreeze<sup>®</sup> Snow Melting Mats and Cables

## Installation Manual

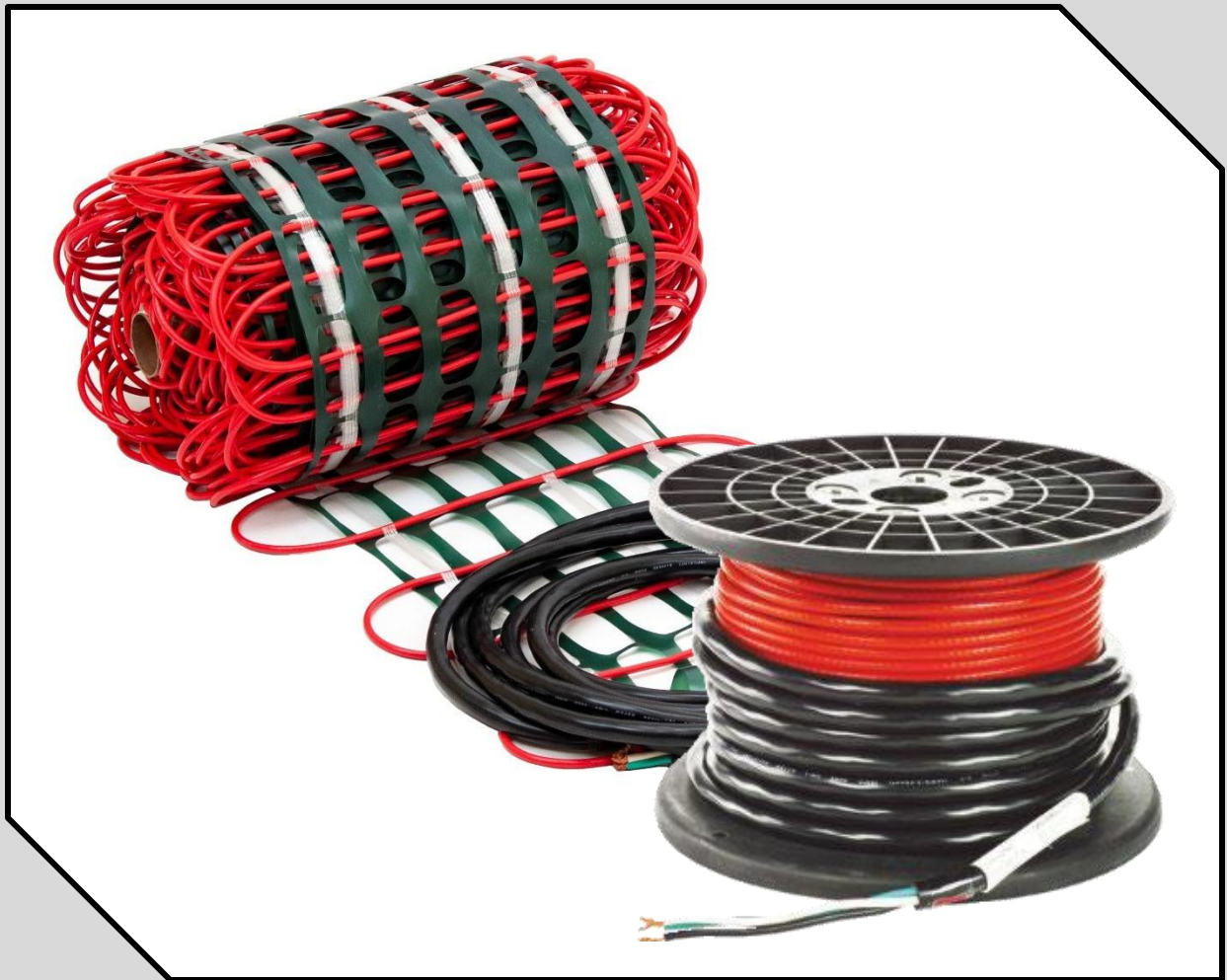

# Table of Contents

---

1	NeverFreeze® Snow Melting Systems .....	2
2	NeverFreeze® Mat/Cable .....	2
2.1	NeverFreeze® Cable Specifications .....	3
2.2	NeverFreeze® Mat Specifications .....	4
3	Warnings .....	5
4	Typical NeverFreeze® Installations .....	7
5	General Installation Guidelines .....	8
5.1	Free Cable and Cable Strapping .....	8
5.2	Turn Techniques for NeverFreeze® Mats .....	9
5.3	Special Applications .....	10
5.4	NF Mats/Cables can be installed in or under a variety of surfaces .....	11
6	Sensor Installation .....	12
6.1	Installing a Feeder Cable .....	12
6.2	Installing a Sensor and a Conduit .....	12
6.3	Placement of Ground Sensors .....	13
6.4	Placement of Individual Ground Sensors .....	13
7	Installing the Heating Mat/Cable .....	14
7.1	Determine General Areas Where You Want to Install NeverFreeze® Mat/Cable. ....	14
7.2	Make a Drawing and Measure the Area Where You Want Snow Melting to Occur .....	14
7.3	Determine Where Junction Box(es) May be Placed to Receive the NeverFreeze® Mat/Cable Power Leads .....	15
7.4	Select the Mat(s) or Cable(s) You Need .....	15
7.5	Consult an Electrician to Make Sure the Mats/Cables, Control, and Design Selected Will Work Properly .....	15
7.6	Verify Everything Before Installation .....	16
7.7	Measure the Resistance .....	16
7.8	Electrical Installation .....	17
7.9	Prepare the Base Material .....	17
7.10	Prepare to Install .....	17
7.11	Begin by Test-Fitting the Mat/Cable in the Area to be Heated .....	17
7.12	Mat and/or Cable Installation .....	18
7.121	Concrete Application .....	18
7.122	Asphalt Application .....	20
7.123	Stone or Paver Application .....	21
7.124	Ceramic or Stone Tile Application .....	22
7.13	Controls and Sensors Installation .....	23
8	Commissioning .....	24
8.1	Insulation Resistance Test with a Megohmmeter .....	24
8.2	Insulation Resistance Test with a Digital Multimeter .....	24
8.3	Heating Cable Resistance Test .....	25
9	Start-up & operation .....	24
10	Troubleshooting .....	25
	Extended Warranty .....	26
	Warranty Certificate .....	26

## **1. NeverFreeze® Snow Melting Systems**

The NeverFreeze® Snow Melting System consists of a controller, a snow (precipitation) sensor, automatic control panel, heating cables or Mats and an optional pavement-mounted snow and ice sensor(s) which provide an economical and efficient means of snow melting and ice protection. The NeverFreeze® Snow Melting System operates automatically by digitally sensing moisture and temperature.

Built for outdoor use, the NeverFreeze® Snow Melting System provides safety and peace of mind to homeowners and business owners alike. Engineered for surfaces such as concrete, asphalt, paver or stone, and ceramic or stone tile, the NeverFreeze® Snow Melting System is both versatile and easy to install. The NeverFreeze® Snow Melting System is completely embedded during the pouring process at which time some controls and accessories should also be installed.

It is recommended to install thermal insulation below the application of the heating cables or mats to improve performance and efficiency and thus decrease overall operating costs.

Installation must be performed by qualified personnel, in accordance with local & national codes, ANSI/NFPA 70 (NEC Article 426) and Section 62 of the CEC Part I.

## **2. NeverFreeze® Cable & Mat**

Installing the NeverFreeze® Snow Melting System provides a permanent solution to the problems caused by cold weather, improves safety by providing reliable relief from snow and ice, and improves your bottom line by reducing the cost associated with applying chemicals, maintaining snow clearing equipment and hiring outside services.

### **Features:**

Ideal for driveways, parking lots, sidewalks, stairs, ramps, bridges and many other applications. For use in concrete, asphalt, under pavers or stone, and ceramic or stone tile.

Single point connection.

Twin conductor cable.

Silent, efficient, and safe.

Emits zero EMF (electromagnetic fields). Easy and flexible installation.

Durable construction.

10-year limited warranty against manufacturing defects, refer to Warranty Card.

## 2.1 NeverFreeze® Cable Specifications

Cable construction	Twin conductor
Rated voltage*	208V, 240V, 480V
Output	15 W/ft (45 W/m) ± 10%
Heating element size	32 ft (9.8 m) to 735 ft (224 m)
Bending radius	1.5 in (38 mm)
Cable diameter	¼ in (6.5 mm)
Conductor insulation	Fluoropolymer and XLPE
Outer Insulation:	PVC
Max.-rated temp.	220°F (105°C)
Min.-installation temp.	40°F (5°C)
Power lead	20-ft (6-m) length

\* - Specified rating will depend on specific model chosen

	SKU	Model	Length	Coverage sq.ft @ Cable Spacing			Output		
				3"	4"	5"	Watts	Amps	Ohms
			Ft.	60W/sq.ft	45W/sq.ft	36W/sq.ft			
208V	TSMC110-208	15SX-1680-20	110	27.5	36.7	45.8	1680	8.1	25.7
	TSMC130-208	15SX-1920-20	130	32.5	43.3	54.2	1920	9.3	22.4
	TSMC160-208	15SX-2400-20	160	40	53.3	66.7	2400	11.6	18
	TSMC190-208	15SX-2850-20	190	47.5	63.3	79.2	2850	13.8	15.1
	TSMC220-208	15SX-3300-20	220	55	73.3	91.7	3300	15.9	13.1
	TSMC285-208	15SX-4250-20	285	71.3	95	118.8	4250	20.5	10.2
	TSMC320-208	15SX-4800-20	320	80	106.7	133.3	4800	23.1	9.1
	TSMC365-208	15SX-5500-20	365	91.3	121.7	152.1	5500	26.5	7.9

	SKU	Model	Length	Coverage sq.ft @ Cable Spacing			Output		
				3"	4"	5"	Watts	Amps	Ohms
			Ft.	60W/sq.ft	45W/sq.ft	36W/sq.ft			
240V	TSMC36-240	SX-0540-24	36	9.0	12.0	15.0	540	2.3	106.7
	TSMC55-240	SX-0810-24	55	13.8	18.3	22.9	810	3.4	71.1
	TSMC90-240	SX-1350-24	90	22.5	30.0	37.5	1350	5.6	42.7
	TSMC165-240	SX-2500-24	165	41.3	55.0	68.8	2500	10.4	23.0
	TSMC220-240	SX-3300-24	220	55.0	73.3	91.7	3300	13.8	17.5
	TSMC255-240	SX-3820-24	255	63.8	85.0	106.3	3820	15.9	15.1
	TSMC290-240	SX-4350-24	290	72.5	96.7	120.8	4350	18.1	13.2
	TSMC330-240	SX-4950-24	330	82.5	110.0	137.5	4950	20.6	11.6
	TSMC370-240	SX-5500-24	370	92.5	123.3	154.2	5500	22.9	10.5
	TSMC420-240	SX-6300-24	420	105.0	140.0	175.0	6300	26.3	9.1

	SKU	Model	Length	Coverage sq.ft @ Cable Spacing			Output		
				3"	4"	5"	Watts	Amps	Ohms
			Ft.	60W/sq.ft	45W/sq.ft	36W/sq.ft			
480V	TSMC330-480	15SX-4900-4	330	82.5	110	137.5	4900	10.3	46.7
	TSMC585-480	15SX-8750-4	585	146.3	195	243.8	8750	18.3	26.3
	TSMC660-480	15SX-9900-4	660	165	220	275	9900	20.7	23.2
	TSMC735-480	15SX-11050-4	735	183.8	245	306.3	11050	23.1	20.8

## 2.2 NeverFreeze® Mat Specifications

Cable construction:	Twin conductor
Rated voltage:*	208V, 240V, 480V
Output (mats):*	45 W/sq ft (485 W/m <sup>2</sup> ) ± 10% at 4 in. center to center
Output (cables):	15 W/ft (50 W/m) ± 10%
Heating element size (mat)*:	4-ft (1.2 m) –91.9-ft (28 m) long x 2-ft (0.6 m) wide
Bending radius:	1.5 in (38 mm)
Cable diameter:	¼ in (6.5 mm)
Conductor insulation:	Fluoropolymer and XLPE (Teflon)
Outer insulation:	PVC
Max.-rated temp.	220°F (105°C)
Min.-installation temp.	40°F (5°C)
Power lead	20-ft (6-m) length

\* - Specified rating will depend on specific model chosen

The remainder of this page is left intentionally blank.

### **3. Warnings**

READ CAREFULLY – It is important to read all of the instructions before installing the NeverFreeze® Snow Melt Systems. Installation must be performed by qualified personnel, in accordance with local codes and manufacturers safeguards. Failure to read all of the instructions can result in fire, electrical shock, property damage, personnel injury and/or death.

#### **Important**

NeverFreeze® Heating Cable = heating cable, factory splice and power lead.

It is important to read the instructions carefully before installing the NeverFreeze® Snow Melting Systems.

- For outdoor installation only.
- NEVER cut or modify the heating cable.
- Extreme care must be used to ensure the NeverFreeze® cables are not damaged when using sharp tools, wheelbarrows, heavy machinery, paving equipment, shovels, rakes, or other equipment. Avoid walking on the cables or mats during installation.
- It is not recommended to install the NeverFreeze® heating systems with a controller that does not contain an integrated temperature limiter.
- The NeverFreeze® heating systems and factory splice must be embedded in mortar or mortar mixture, concrete, sand or asphalt.
- The power lead, the non-heating portion of the system, and cable connection (splice) must be at least 1 ft (30 cm) embedded in concrete or other paved surface.
- NEVER pull any of the heating cable or factory splices into any conduit. Remaining power lead should be run through the conduit.
- The power lead may be extended or cut shorter if required but must never be removed from the heating cable.
- Do not install the NeverFreeze® cables in such a manner that two heating cables touch, cross, in- stalled closer than 2 inch of each other or power lead, or overlap each other.
- Do not install heating cable closer than 2 inches to another heating cable, power lead cable, and underground cable or piping. Proper spacing is necessary to avoid overheating the cable.
- Always keep ends of the power leads dry before and during installation.
- Remember to always measure, verify and record the actual resistance throughout the installation process:
  - Out of the box
  - After installation
  - Before pouring the sand/concrete/asphalt
  - After surface material application
  - Before energizing the cables for the first time
- Record these values on the test log sheet and mail it in. Failure to do so will void the warranty.
- Measure the resistance between two resistance conductors as well as the resistance between each conductor and the ground wire.
- ThermoSoft® recommends using a megohmmeter to test the insulation resistance.
- Never attempt to repair a damaged cable. Contact ThermoSoft® for assistance.
- Remember to check that the supply voltage matches the voltage required for your particular NeverFreeze® product.
- Remember to place the labels as instructed in this manual.
- Always de-energize all circuits before installing or servicing.
- Always provide ground fault protection (GFEP) for the NeverFreeze® Snow Melting System. Ground fault protection may be in the form of a breaker in the panel or as a part of the control panel.
- Always install in accordance with all local codes and the National Electrical Code (ANSI/NFPA 70 especially Article 426) and Section 62 of the Canadian Electrical Code (CEC) Part I.
- This heating system requires a controller with temperature limiting device.
- Please consult ThermoSoft® for any other questions, concerns or advice.

#### 4. Typical NeverFreeze® Installations

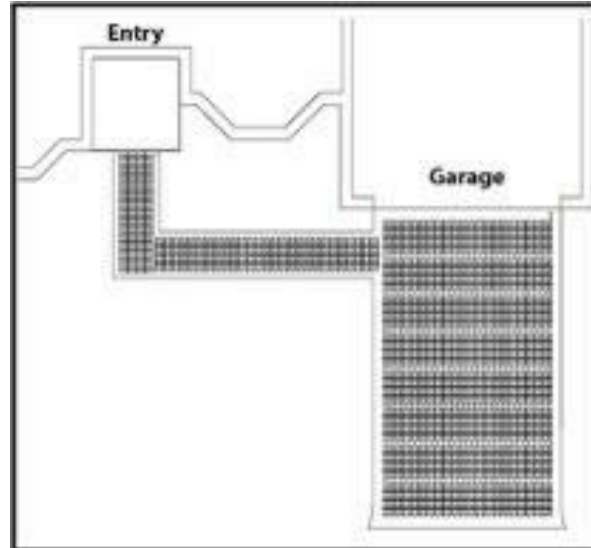
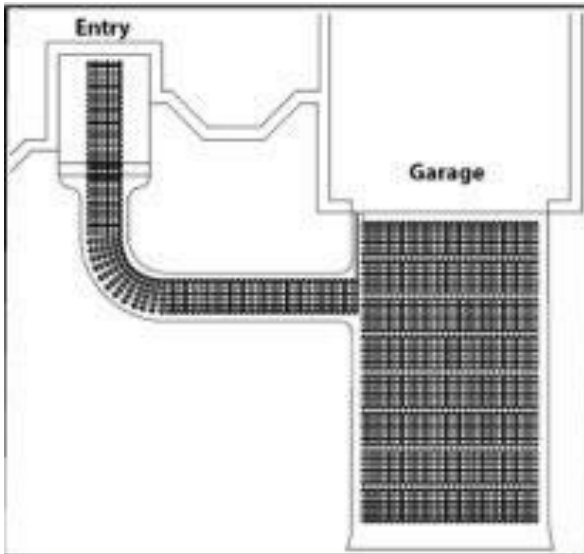
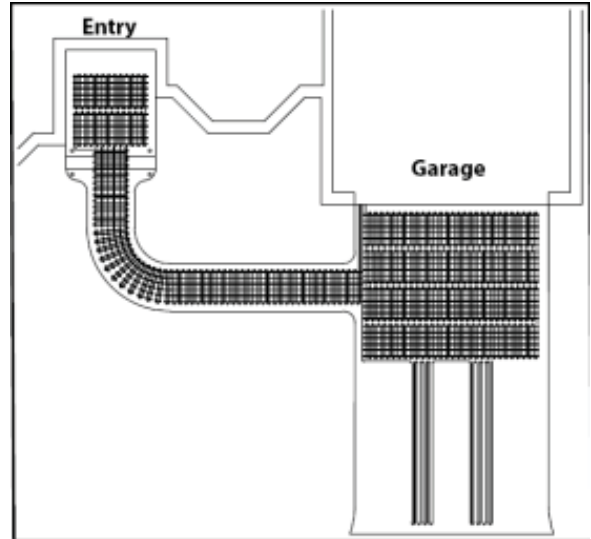
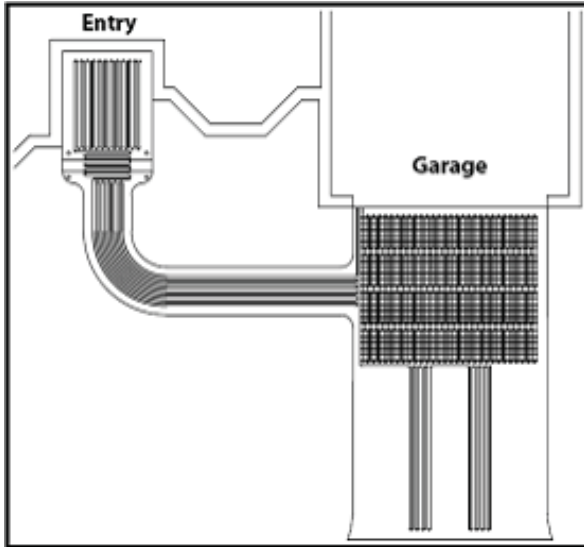

Driveway with full coverage near garage and "tire track" coverage down driveway. NeverFreeze® Mats and cables can be used in combination to fit a variety of areas.

NeverFreeze® mats and cables can be used in combination to fit a variety of areas.

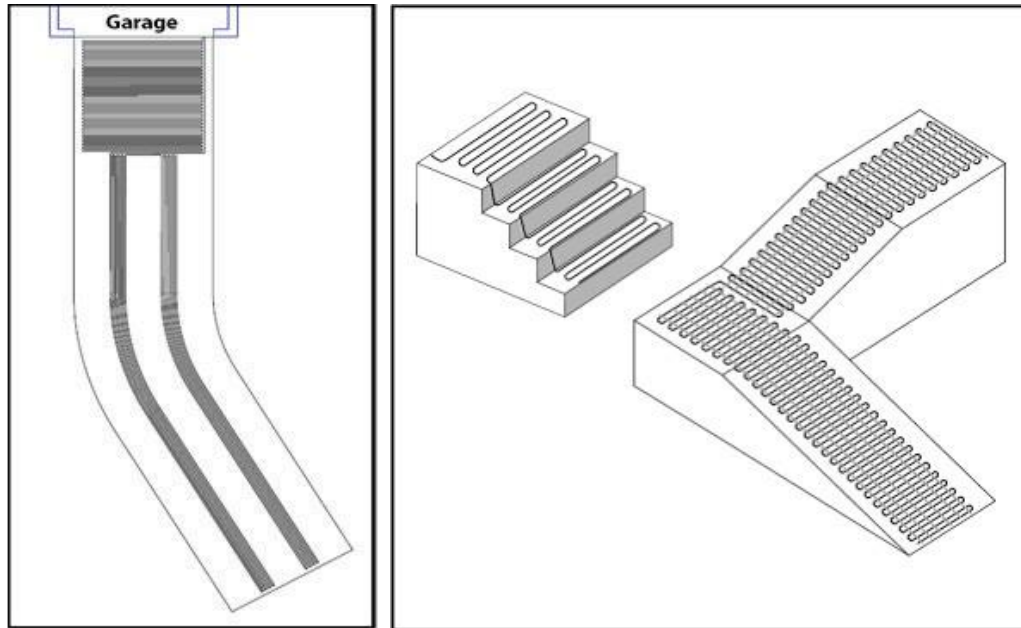

## 5. General Installation Guidelines

### 5.1 Free Cable and Cable Strapping

If the cable is to be laid on top of an existing slab, select enough FixFast® cable strap to secure the cable to the surface.

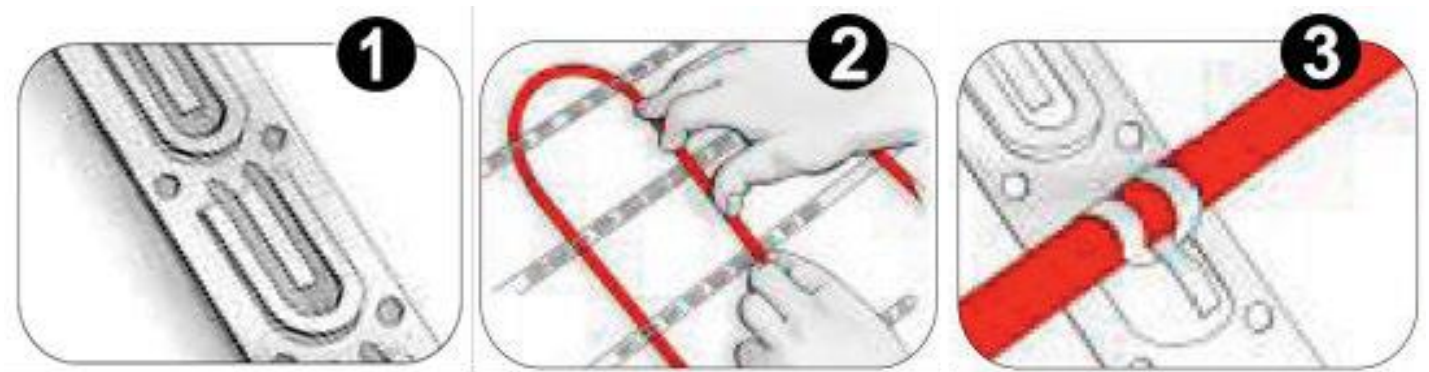

Attach the cable strapping to the ground surface (3–4 ft apart)

Clip the cable in place

Place the cable 3-4 in standard spacing

## 5.2 Turn Techniques for NeverFreeze® Mat alterations

If you need to cut and turn the mat, or fill odd areas, you may use scissors to carefully cut the mesh or tape holding the heating cables. Heating cables should be secured at 5 inches apart (36 W/ sq.ft), 4 inches apart (45 W/sq.ft) or no less than 3 inches apart (60 W/sq.ft).

### **Important**

Be careful not to kink or sharply bend the heating cable. A minimum bend radius of 1 inch should be maintained.

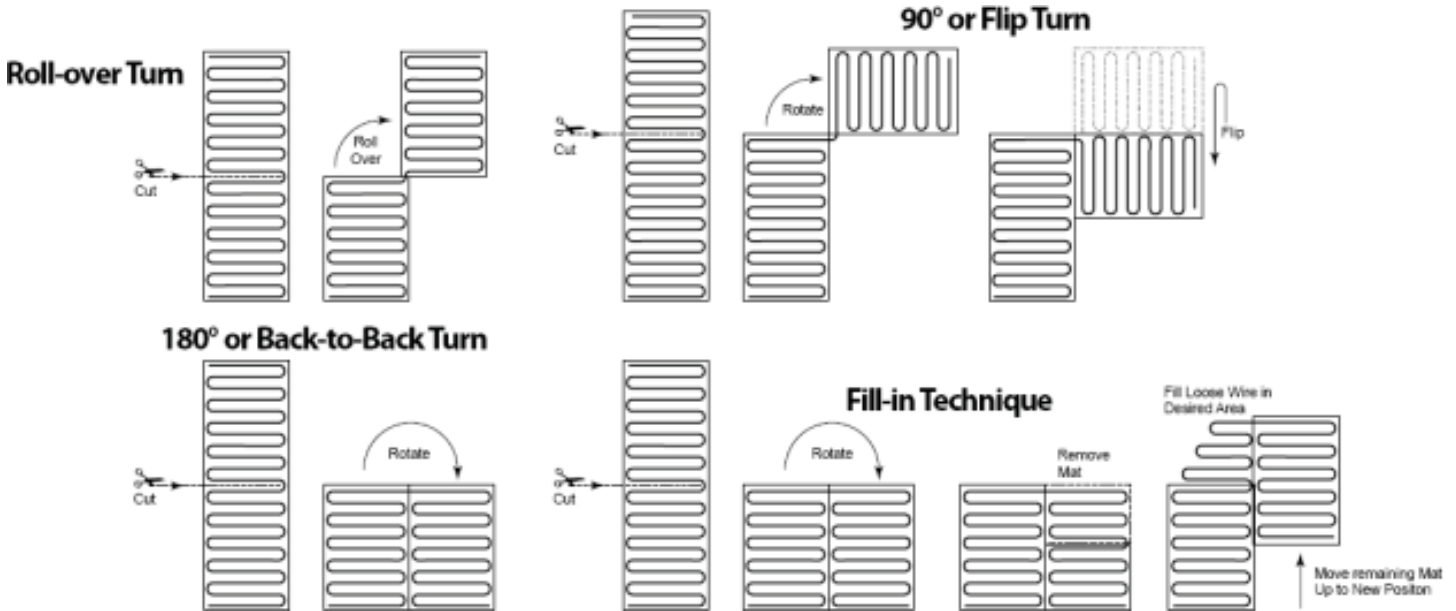

## 5.3 Special Applications

**Stairs:** If you are installing a NeverFreeze® mat onto stairs, carefully cut the tape holding the heating cable. If installing a NeverFreeze® cable, skip the previous step. Secure a single run of cable to the side of a riser. Lay 3 or 4 runs of cable on the tread area as needed and continue up each stair. Follow these guidelines:

- Lay cable no greater than 3 inches from the front edge of the finished tread. Otherwise this edge may not melt snow properly.
- Lay cable no less than 6 inches from the side edges of the finished tread.
- Account for future hand railings that could be mounted onto the tread, especially in the middle of a long tread if required. Use a marker or indicate on drawings where the railing anchors may be installed safely later.
- Avoid pinching or sharply bending the cable. At the corner of the riser and tread keep a minimum 1-inch radius bend but secure the cable flat enough that the surface concrete or pavers will not pinch it.
- Do not install the mat/cable on or under non-masonry stairs such as wooden or composite construction.

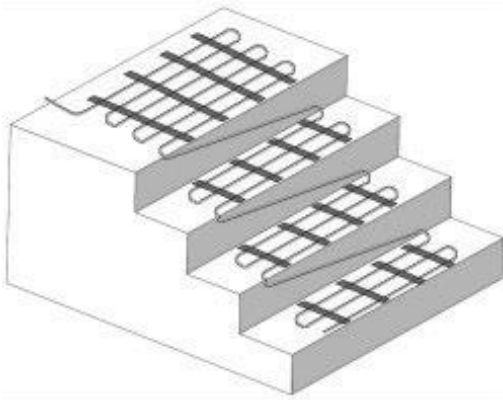

NeverFreeze® mat on stairs

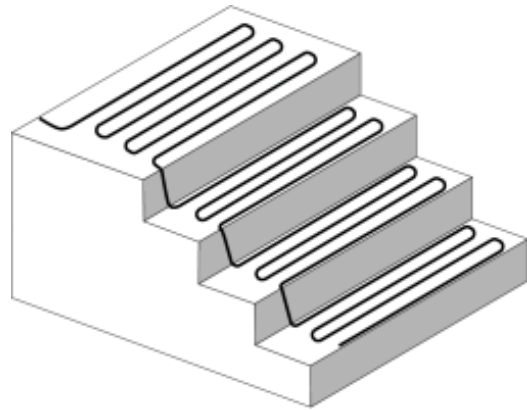

NeverFreeze® cable on stairs

Expansion Joints: NeverFreeze® heating cable must never be run through an expansion joint. Doing so may cause damage to the cable with slab movement. It is recommended to lay the mat so these joints are avoided. Match your zones within expansion joints, if possible.

However, if it is necessary, a rebar coated with epoxy is the best mean to cross a joint. It must be embedded 6 inches deep both sides of the joint. Or use an angle iron to protect the cable if laid on existing concrete pad. See below.

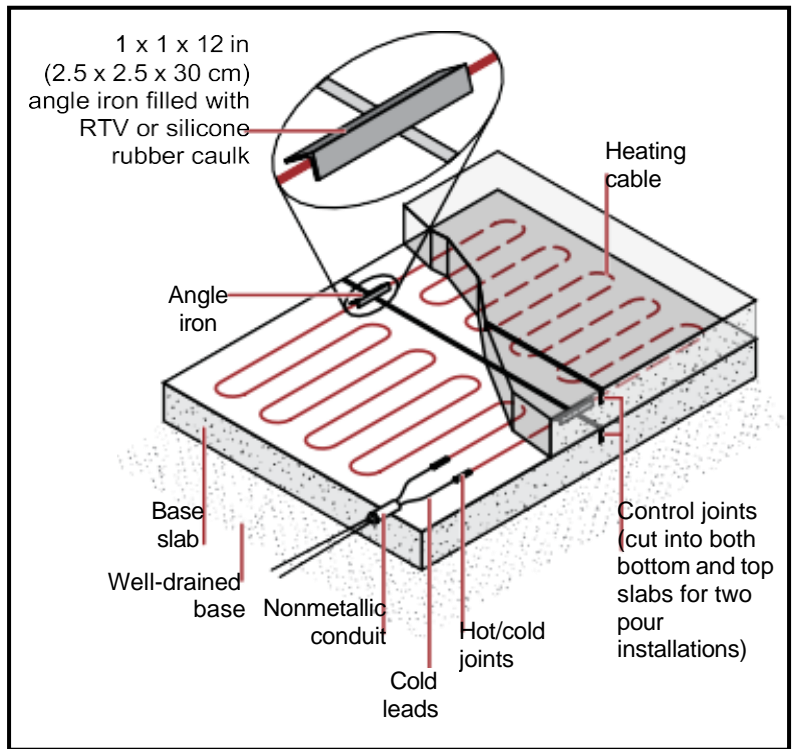
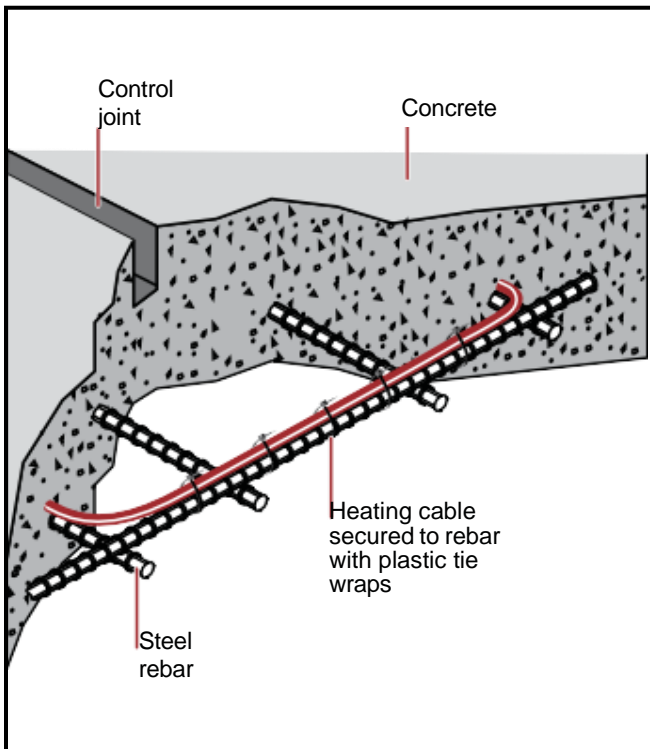

There is an alternate solution if rebar is not used. The heating cable may be run down into a sand box below the expansion joint as shown. Run the cable into sand to a depth of at least 1 inch. The loop of cable created should be long enough to allow flexing.

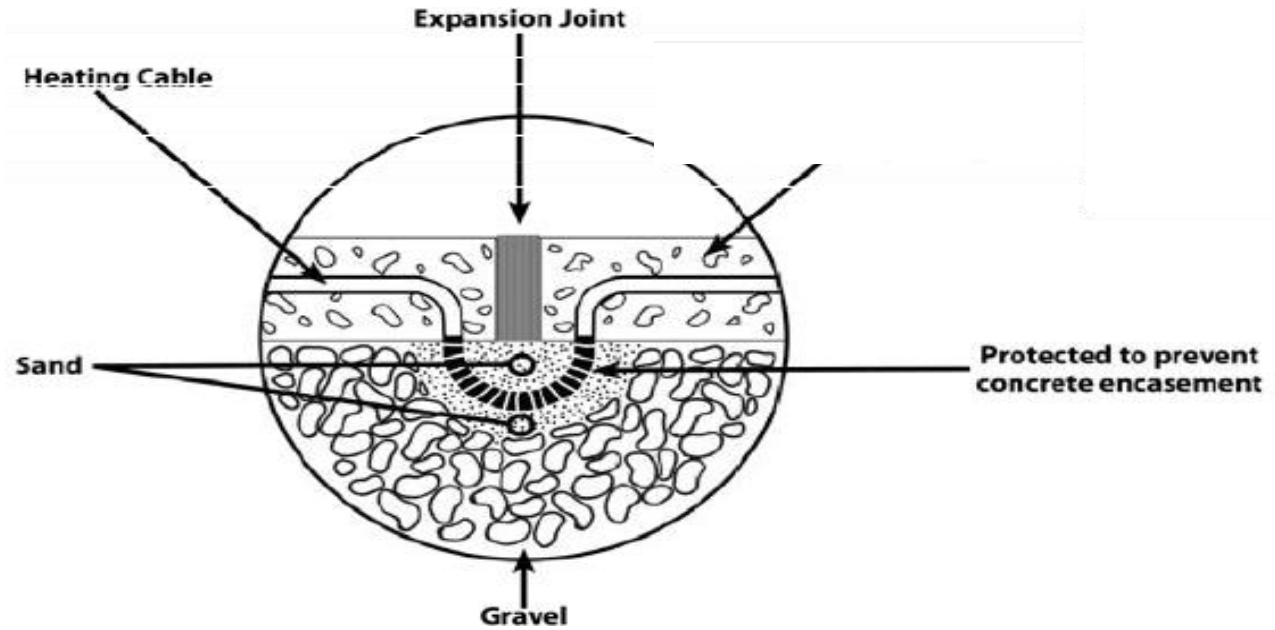
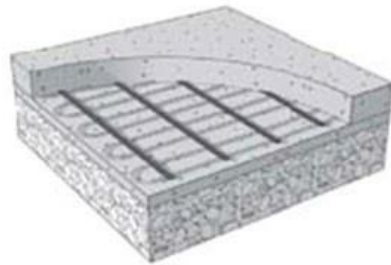
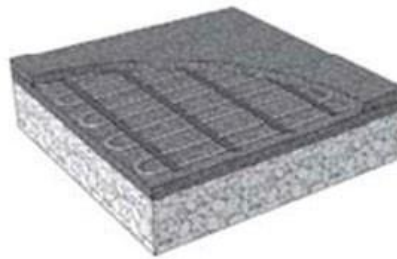

Figure 1: Expansion joint

5.4 **NeverFreeze® Mats/Cables can be installed in or under a variety of surfaces**



NeverFreeze® embedded in concrete



NeverFreeze® embedded in asphalt

If the product is installed on a wire mesh or rebar, lay the cable at the specified interval and secure the cable with cable ties at 12 to 24 inch interval. Do not overtighten the ties to prevent damaging the jacket or insulation.

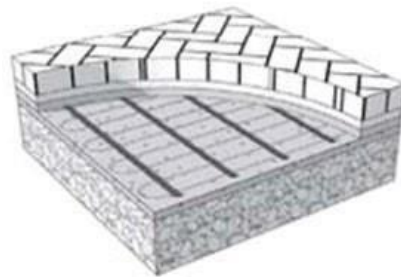

NeverFreeze® under brick pavers



NeverFreeze® under tile

## 6. Sensor Installation

### 6.1 Installing a Feeder Cable

A feeder cable (extension) for a sensor might be needed. A 50-ft (15-m) cable is supplied with each sensor. Approx. 1.5 ft (0.5 m) of the feeder cable should be coiled at the bottom of the sensor housing, for servicing. The remaining cable may be lengthened. The feeder cable must be a four-wire cable to match the sensor wiring.

### 6.2 Installing a Sensor and a Conduit

The sensor and the conduit may be installed in connection with the actual construction work and connected at a later date. The following applies for all types of installations:

- Ensure that the conduit is sealed and the housing cover is in place before the concrete is poured.
- The sensor housing must be positioned so that it is flush with the surrounding terrain. Later on, the sensor must be adjusted so that the top brass surface is level (horizontal).
- The base below the housing must be hard; for example, a concrete tile. This hard base ensures that the sensor is not pushed into the ground if, for example, a vehicle runs over it. The tube is designed to be mounted on a plate using the two screw holes inside the conduit.
- Run a metal/plastic conduit between the sensor housing and an indoor or outdoor junction box.
- From the opening of the housing, coil approx. 1.5 ft (0.5 m) of the sensor cable inside the conduit.
- Use plumbing putty to seal the inside of the housing and to seal the conduit gap.
- Once the surface is cured, place the sensor inside the housing until it is horizontally flush with the edge of the conduit and resting on the internal collar inside the conduit. The sensor may be extracted at a later date using the two or three screws found around the edge of the sensor conduit. The grooves on the outside of the sensor should correspond with the holes in the conduit.

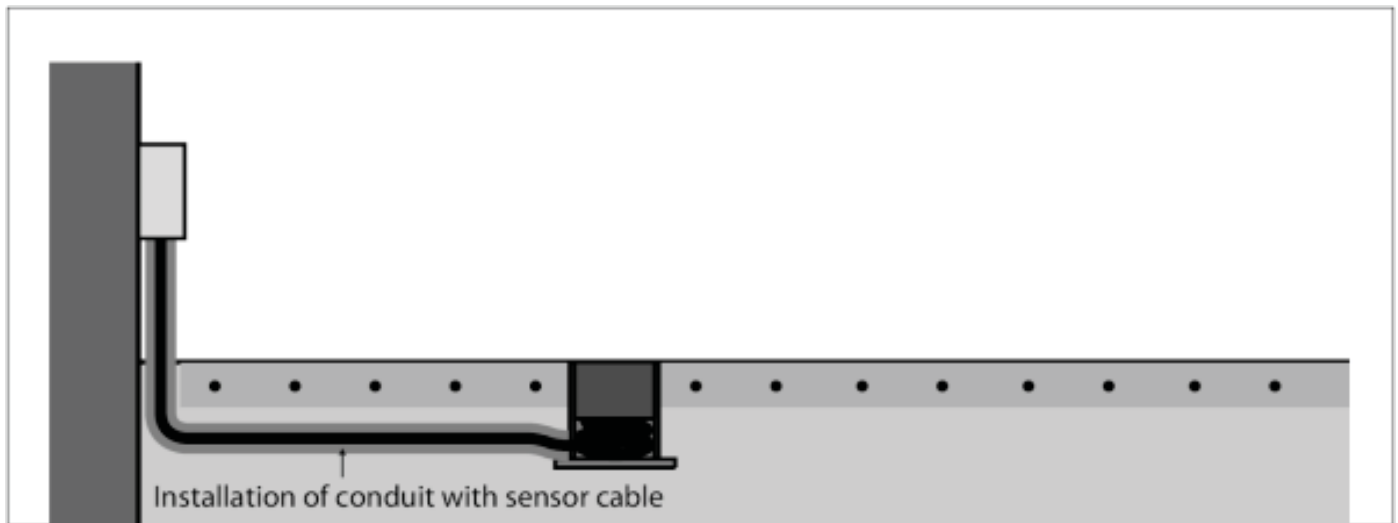

### **Important**

**Installation in Asphalt:** The temperature must not exceed 176 °F (80 °C) around the sensor/tube. A wooden block or housing cover may be used to prevent material ingress. Use a high temperature plastic or metal conduit and housing that can withstand the heavy load of the application.

### 6.3 Placement of Ground Sensors

The number of ground sensors used and their correct placement is an important factor for the system to work as intended. Follow these guidelines:

- The more sensors added to the system, the better the performance.
- The basic principle is to place one sensor where the snow/ice will appear first (for fast detection) and one sensor where the snow/ice will disappear last (for complete melting). If this is not obvious, place the sensors as far apart from each other as possible.
- With only one sensor you will have to decide on the most important factor:
  - Fast detection and activation of the system or
  - Complete melting of all snow/ice.
- A one-sensor ground system will be slower in terms of detection and activation than a two-sensor ground system.
- With more than two sensors it is possible to cover problematic spots where snow usually is not detected or where snow is not completely melted when the system stops.

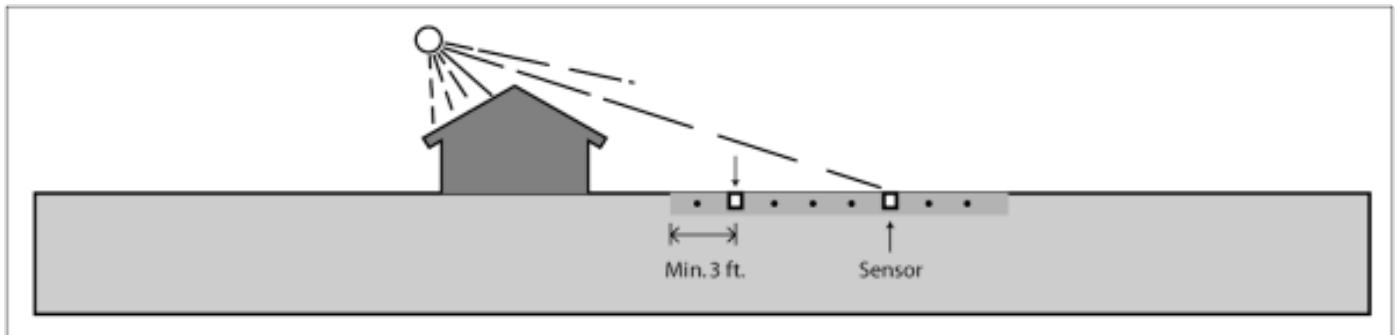

### 6.4 Placement of Individual Ground Sensors

- The sensor must be placed within the heated area and at least 3.3 ft (1 m) from the edge of the area if possible.
- The sensor must be placed in between the heating cables equally spaced out. A distance of minimum 0.4 in (1 cm) should be maintained between the sensor tube and the heating cable.
- There must be a minimum distance of 3.3 ft (1 m) between the two sensors.

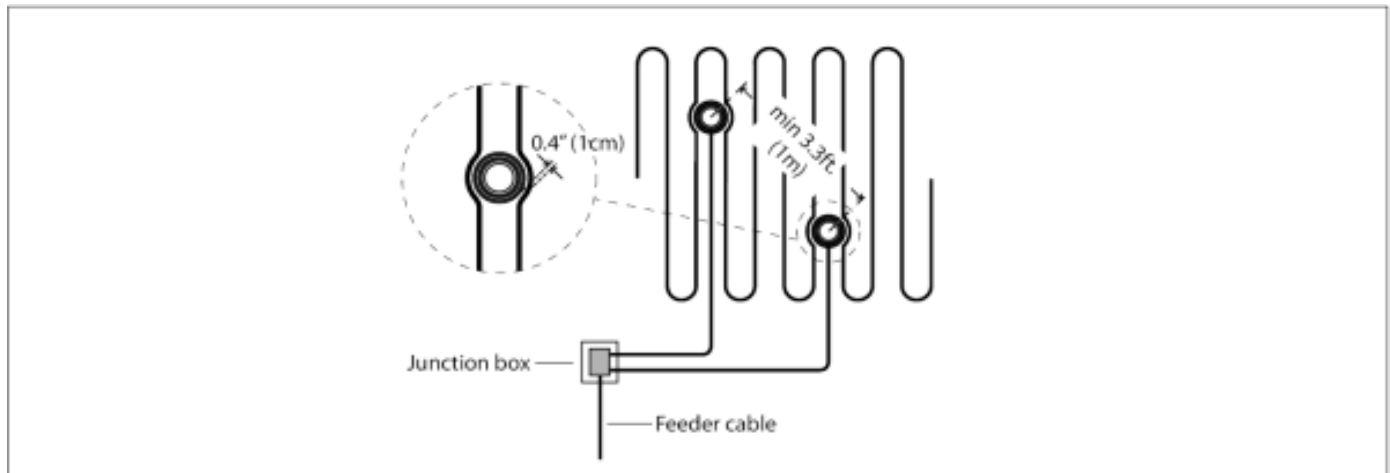

## 7. Installing the Heating Mat/Cable

### 7.1 Determine General Areas Where You Want to Install NeverFreeze® Mat/Cable

Applications include driveways, walkways, patios, permanent ramps, masonry steps and benches, shipping docks, under garage door sill and more. Any outdoor location in residential or commercial where snow or ice accumulates may be considered as long as the NeverFreeze® mat/cable is completely embedded in concrete, sand, thick mortar bed, or asphalt.

NeverFreeze® mat/cable cannot be installed indoors, in industrial locations, or areas requiring a hazardous classification. It cannot be used for gutter or pipe freeze protection or roof snowmelt. Do not install the mat/cable on or under non-masonry stairs or decks such as wooden or composite construction.

If installing NeverFreeze® under brick pavers, we recommend installing cables under the entire area. This is because the non-heated area will receive melt water that may re-freeze under the pavers causing the pavers to heave in the non-heated area.

If you have an application you are unsure of, please call ThermoSoft® for advice.

### 7.2 Make a Drawing and Measure the Area Where You Want Snow Melting to Occur

Eliminate those areas where NeverFreeze® cannot be installed, keeping in mind the following obstructions and allowances:

- Mat/cable must not be laid within 6 inches of the edges of slabs. In asphalt, increase this distance to 12 inches from the edge where no curb is provided.
- Avoid crossing expansion joints in a slab unless proper technique and precautions are followed (see Section 5.3).
- Avoid placing the heating cable any closer than 2 inches from other items such as underground cable or piping to prevent the cable from overheating.
- Allow at least 2 inches but no more than 4 inches between adjacent cables, and between adjacent cables and sections of a mat where the mat is cut and turned to fill the area.
- Mat/Cable must be laid such that the surface above it will not have any type of obstruction (such as pedestals, support columns, walls, light posts, etc.). Such surface obstructions can capture heat or cause the cable to be damaged by mounting brackets, bolts, etc.

Also, consider the following precautions:

- The power lead/heating cable joint and a minimum of 1 foot of power lead must be embedded in the paving surface.
- **The heating cable and factory splices of NeverFreeze® mat/cable must be completely embedded in the concrete, sand, or asphalt. NEVER lay excess heating cable in surrounding soil, walls, or other unprotected applications. Instead, change your cable pattern.**
- NEVER overlap the heating cable on itself or place heating cable closer than 2 inches from other heating cable.
- Only the power lead may exit this area. It will be pulled through conduit to protect it up to a junction box. NEVER pull any of the heating cable or factory splices into any conduit.

#### Warning

THE HEATING CABLE CANNOT BE CUT TO LENGTH. Order the correct size mat or cable to fit the area. Modifying the heating cable is not allowed and may lead to overheating, damage, and fire hazard.

See Section 4 for typical installations.

### 7.3 Determine Where Junction Box(es) May be Placed to Receive the NeverFreeze® Mat/ Cable Power Leads

Determining the location of the junction box(es) is important to ensure the mat(s) and/or cable(s) you select fill the area correctly and with the best connection locations.

It is best to locate junction boxes on a wall indoors and within the distance of the power leads on the mat/cable. NeverFreeze® mat/cable comes standard with 20-foot long power leads.

If a junction box must be located outdoors, it is recommended it be installed above grade and be properly rated for rain-tight use outdoors. If it must be installed at or below grade, use properly rated watertight items and follow the manufacturer's guidelines for protection and connection seals.

### 7.4 Select the Mat(s) or Cable(s) You Need

**WATTAGE:** Select the heating output required. Your design must consider weather conditions and how critical it is to clear the heated area, and your geographical location.

- 36 watts per square foot is sufficient to clear most light to moderate snowfall rates
- 45 watts per square foot is sufficient to clear most moderate and heavy snowfall rates
- 60 watts per square foot is sufficient to clear very heavy snow fall rates

**SIZE:** Select a mat in Table 1 or a cable in Table 2 to fit the heated area measured in Step 7.2 NeverFreeze® mat/cable is manufactured in a variety of sizes as shown. If the exact size of mat or cable is not found in the table, select the next smaller cables size.

**AMPS and VOLTS:** Pay careful attention to the current (amps) to make sure your controls, circuit breaker panel, and all wiring will have the proper capacity. Design circuit protection and wiring to handle 125 percent of heating cable load (see applicable code):

BREAKER SIZE	MAXIMUM SIZE
20 amp circuit	Load up to 16 amps
30 amp circuit	Load up to 24 amps
40 amp circuit	Load up to 32 amps
50 amp circuit	Load up to 40 amps
70 amp circuit	Load up to 50 amps

### 7.5 Consult an Electrician to confirm the Mats/Cables, Controls, and Design Selected Will Work Properly

- The NeverFreeze® Mat/Cable and its control must be placed on a dedicated power supply from the circuit breaker panel.
- The NeverFreeze® Mat/Cable is a resistance heating system and should be considered as a continuous load for branch circuit sizing purposes.
- The circuit breaker must open all ungrounded conductors at the same time. A Ground Fault Equipment Protection (GFEP) type (typically Class B, 30 mA trip) is required to directly protect the NeverFreeze® mat/cable.
- Circuit breaker size and circuit wiring should be designed to 125 percent of heating mat load. (SEE ABOVE TABLE)
- Follow NEC, CEC, and local code guidelines for branch circuit wiring, conduit, and junction box installations. Outdoor and underground junction boxes and conduit must meet rain tight or watertight specifications as required.

## 7.6 Verify Everything Before Installation

Remove the NeverFreeze® Mat/Cable, control, and sensor from their packages. Inspect them for any visible damage and verify everything is the correct size and type according to your plan and order. Do not attempt to install a damaged product.

Record the mat/cable information in Warranty Registration form found in the box. It is important to retain this manual and the information recorded during installation. The mat/cable model number, serial number, voltage, and resistance range are shown on a nameplate label attached to the power leads. Do not remove this nameplate label. The nameplate label is required by the electrical inspector.

### **Important**

Before installing NeverFreeze® mat/cable, make sure to fully check the products as above, and carefully plan your site. The following steps may not necessarily occur in the order shown depending on contractor and electrician scheduling and variations in site preparation requirements. Clear communication between all parties involved will help eliminate costly errors and potential damage.

## 7.7 Measure the Resistance

- Use a digital multimeter to measure the resistance between the conductors of the mat power leads. Record these resistances in the Warranty Registration Form under Reading 1 (before installation). The resistance between the white and black lead wires should be within the resistance range on the nameplate label. If it is slightly low, it may be due to low air temperatures or meter calibration. Consult ThermoSoft® if you are in doubt. Please refer to Section 8.3.
- The resistance between the white and black leads and ground lead should be “open”, usually indicated by an “OL” depending on your meter (whatever the meter indicates when the test leads are not touching anything). If there is any change in the reading, record this information and contact ThermoSoft® before installing. A change in reading may indicate damage, test lead problems, or a number of other issues. Try “pinning” the test leads to the mat/cable lead wires against a hard non-metal surface if the readings fluctuate. Please refer to Section 8.2.
- An electrician should perform an insulation resistance test on the mat. A megohmmeter adjusted to a minimum 1000 VDC should give a measured value at least 20 megohms (M $\Omega$ ). Please refer to Section 8.1.



### **Warning**

Megohmmeters apply high voltage and could shock or cause serious injury if improperly used. Follow the manufacturer's instructions for safe and proper use.

- The InstAlarm® monitor shown at right will constantly monitor the heating wire during the entire installation process. If the wire is cut or damaged during installation, this device sounds an audible alarm. The InstAlarm® monitor will prevent burying a damaged wire below hardened concrete.



## 7.8 Electrical Installation

- Install junction boxes in the location(s) planned during the design process (see Section 7.3).
- Install conduit and branch circuit wiring from the circuit breaker panel to the control location and from the control to the junction boxes. Follow local code for wire size, conduit requirements, and proper installation procedure.
- Install conduit from the junction box to the edge of the slab to be heated. Extend this conduit into the slab edge about 2 to 6 inches inward and attach a bushing to the end to prevent damaging the mat/cable power leads.
- Follow electrical code for burial depth of the conduit.
- Plan carefully if you are installing edge pavers, edge drainage systems, landscaping, or other items that affect where the conduit comes in.
- If a slab sensor is to be embedded in the heated area, install conduit from the control location to the desired slab location. Follow the sensor instructions for proper placement and connections.
- Install the circuit breaker size and type as determined earlier in Section 7.5. DO NOT connect the branch wiring to the breaker yet.
- Label the circuit breaker in the panel which feeds this Snow Melt System.

## 7.9 Prepare the Base Material

- Prepare the site that you want to heat with NeverFreeze® mat/cable. This includes making sure all utilities and obstructions are considered.
- Lay a smooth, well-compacted gravel base. Ensure proper slope and drainage to avoid water buildup in any heated or surrounding areas. This is especially important for brick paver applications as melted water may re-freeze and heave surrounding sand and paver areas. Follow local building code and construction guidelines for grade thickness and type.
- Insure to account for the total grade and slab thickness as required for pedestrian and vehicular traffic use.
- If the mat/cable is to be placed on an existing pavement, insure it is inspected for any sharp objects, loose sections, or other potentially damaging conditions that could cause problems. It is required for the cable to be completely embedded.

## 7.10 Prepare to Install

- Determine a time to install the mat/cable when equipment, heavy tools, and site traffic will be minimal to keep from possibly damaging the product. Be prepared to install the surfacing over the mat/cable the same day to avoid the possibility of damage.
- If installing mat/cable in the upper layer of a two-stage concrete slab or the upper layer of an asphalt application, the mat or cable should be completely ready for the second stage. There is limited time between stages as the slab should not be allowed to fully cure or the asphalt to completely cool. Therefore, if using NeverFreeze® cable, you may want to lay it out and tie it to the rebar that can be quickly lifted into place after the first layer is laid. This might also be preferable for a mat installation, although if mats are precut and shaped to the area they generally can be rolled into place fairly quickly. If a slab sensor is installed in the second layer, plan ahead to ensure the first layer does not cure or cool too much.
- Inspect the area and remove any sharp objects.
- Install in temperatures at least 40°F (4.5°C) and above.

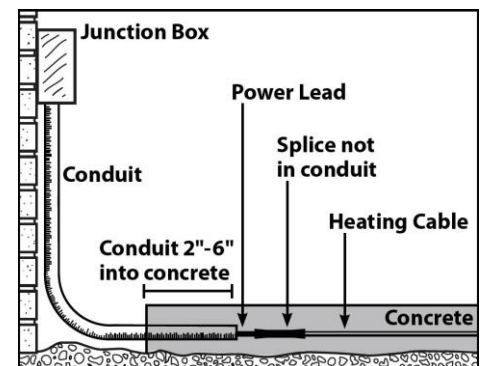

## 7.11 Begin by Test-Fitting the Mat/Cable in the Area to be Heated

For mat, unroll it completely. Turn and flip it by cutting the tape where needed. Make sure it fits the area properly. For cable, make sure it fits the area with no excess cable.

\*Over temperature (OT) sensor installation required.

## Important

This heating cable CANNOT be cut shorter to fit! Do not overlap or cross over heating cable on itself. Do not space out heating cable closer than 2 inches.

- Mat/cable must not be laid within 6 inches of the edges of slabs. In asphalt, increase this distance to 12 inches from the edge where no curb is provided.
- Avoid crossing expansion joints in a slab unless proper technique and precautions are followed (see Section 5.3).
- Avoid placing the heating cable any closer than 2 inches from other items such as underground cable or piping to prevent the cable from overheating.
- Allow at least 2 inches but not more than 4 inches between adjacent cables, and between adjacent cables and sections of a mat where the mat is cut and turned to fill the area.
- Do not repeatedly bend the heating cable, and never bend factory splices.
- Place the power leads of the mat/cable next to the conduit entry. The electrician will pull this through the conduit later. Make sure it is positioned so that no part of the splice connection or the heating cable will be pulled into the conduit.

Take into consideration the total thickness of the finished slab and plan to have the heating cables located no deeper than 2 to 3 inches from the top surface. Embedding the cables deeper will slow the temperature ramp up time and the total performance of the system. Cables embedded as deep as 4 to 6 inches will seriously affect the performance and could render the system almost useless.

- A colder slab may partially melt and not melt the accumulated snow or precipitation.
- Insulation should be installed underneath the heating cable system to improve its efficiency and minimize the ramp up time. In some installations, it is necessary like under stairs or open balcony.

### Warning

The heating cable and factory splices of NeverFreeze® mat/cable must be completely embedded in the concrete, sand, or asphalt. Never try to use up excess heating cable in surrounding soil, walls, or other unprotected applications.

## 7.12 Mat and/or Cable Installation

### 7.12.1 Concrete Application

- Step 1: Attach reinforcement, such as wire mesh or rebar, over the base at about 2 inches below the level of the top surface. Use a brick or cinder block as “chair” to raise the wire mesh to the correct level. The NeverFreeze® mat/cable will be attached to this reinforcement later. It is very important for the cable to be completely embedded in concrete. Protect or remove sharp protrusions by bending them over, capping, or cutting. Sharp edges may damage the heating cable.
- Step 2: (NeverFreeze® Mat) Begin laying out and securing the mat about every 2 feet to the reinforcement mesh or rebar using plastic cable ties around the heating cable. Turn the cable tie ends downward or trim them so they will not poke up through the surface layers. Do not use metal ties as they may damage the cable.  
If installing on top of existing slab, secure the mat by nailing through the tape approximately every 2 feet. NEVER strike the heating cable with a hammer.
- Step 2: (NeverFreeze® Cable) Begin securing the heating cable at the desired spacing to the reinforcement mesh or rebar using plastic cable ties. Apply the cable ties at the ends of each run and at every 3 to 4 feet. Turn the cable tie ends downward or trim them so they will not poke up through the surface layers. Do not use metal ties as they may damage the cable.  
If installing on top of existing slab, secure cable strap to the surface. Attach cable strap with nails every 6 to 10 inches. Cable strap should be placed at either end of the heated area, and additional straps should be applied every 3 to 4 feet in between to hold the cable in place during surfacing.
- Step 3: Use a digital multimeter to measure the resistance between the conductors of the mat/ cable power leads again. Record these resistances in the Warranty Registration form AFTER MAT/CABLE IS SECURED IN PLACE.



Please refer to Section 7.7.

- Step 4: Feed the power leads through the conduit into the junction box, leaving at least 6 inches of free lead length. Secure the heating cable and splice so that they will not be pulled into the conduit. Insert a generous amount of electrical conduit seal-ant into the conduit end around the power leads to prevent water entry.
- Step 5: If a slab sensor is being installed, place the sensor socket according to the instructions. Secure and seal it to the conduit installed earlier. It should be located halfway between heating cables and in an area that is recommended by the sensor manufacturer. Insure the top of the sensor will be flush with the surface of the finish layer but leveled. Make sure it is protected with a cap or seal.
- Step 6: Take a photo of the mat/cable installation grid. This can be very helpful later for utility work, changes to the site, etc., to avoid damaging the cable. Keep the photos with this installation manual.
- Step 7: Before beginning work, inspect the mat/cable for damage and secure any mat/cable that may have come loose.

To avoid burying any possible damage that may have occurred since the mat was laid, the following tests must be performed:

Use a digital multimeter to measure the resistance between the conductors of the mat/cable power leads again (see Section 7.7). If possible, an electrician should perform an insulation resistance test on the mat/cable. A megohmmeter adjusted to a minimum 1000 VDC should give a measured value at least 20 megohms (M $\wedge$ ).

### **Important**

Be prepared to install a marker plate or other identification indicating the presence of NeverFreeze $\text{\textcircled{R}}$  in the slab. This helps to alert anyone doing future work on the site of the presence of NeverFreeze $\text{\textcircled{R}}$  cable/mat to prevent inadvertent damage. Install a marker plate where clearly visible in each snow-melted area. A marker plate is placed flush in the wet concrete surface or soft asphalt surface. Other types of surfaces should be made to allow the marker plate to be installed flush with the surface. Take care not to damage the heating cables.



- Step 8: Pour concrete over the base and NeverFreeze $\text{\textcircled{R}}$  Mat/Cable so that no less than 1-1/2 inches and no more than 3 inches covers the top of the heating cables. The slab should be a minimum thickness of 4 inches in total. Driveways normally require thicker slabs. Follow building code requirements for required thicknesses.

### **Important**

Do not use sharp tools which could damage the NeverFreeze $\text{\textcircled{R}}$ . Blunted shovels should allow you to work the concrete carefully into all areas.

Make sure the heating cable is fully embedded as well as 2 to 6 inches of the conduits enclosing the power lead and slab sensor wiring (if used).

Allow the concrete to fully cure as required by the concrete supplier. Do not energize the NeverFreeze $\text{\textcircled{R}}$  Mat/Cable except to briefly test it, as this would improperly accelerate the curing and potentially cause concrete damage.

- Step 9: Use a digital multi-meter to measure the resistance between the conductors of the mat/ cable power leads again. Record these resistances in the Warranty Registration form AFTER COVERINGS ARE APPLIED. Please refer to Section 7.7.

### 7.12.2 Asphalt Application

- Step 1: Apply a first course over the gravel base and compact it. The NeverFreeze® Mat/Cable will be secured to the top of this later. Allow it to cool enough to work on before installing NeverFreeze® Mat/Cable.
- Step 2: (NeverFreeze® Mat) Begin laying and securing the mat to the first course, using nails, staples or similar into the mat tape every 2 feet or so. Make sure it is laid flat. Do not use metallic nails or staples directly over the heating cable. Be careful not to damage the heating cable.
- Step 2: (NeverFreeze® Cable) Secure zip ties to the surface. Use nails or similar, every 6 to 10 inches. Zip ties should be placed at either end of the heated area, and additional straps should be applied every 3 to 4 feet in between to hold the cable in place during surfacing.
- Step 3: Use a digital multimeter to measure the resistance between the conductors of the mat/cable power leads again. Record these resistances in Table 3 AFTER MAT/CABLE IS SECURED IN PLACE. Please refer to Section 7.7.
- Step 4: Feed the power leads through the conduit into the junction box, leaving at least 6 inches of free lead length. Secure the heating cable and splice so that they will not be pulled into the conduit.

Insert a generous amount of electrical conduit sealant into the conduit end around the power leads to prevent water entry.

- Step 5: If a slab sensor is being installed, place the sensor socket according to the instructions. Secure and seal it to the conduit installed earlier. It should be located halfway between heating cables and in an area that is recommended by the sensor manufacturer. Make sure the top of the sensor will be flush with the surface of the finish layer. Make sure it is protected with a cap or seal.
- Step 6: Take a photo of the mat/cable installation. This can be very helpful later for utility work, changes to the site, etc. to avoid possible damage. Keep the photos with this installation manual.
- Step 7: Before beginning work, inspect the mat/cable for damage and secure any mat/cable that may have come loose.



To avoid burying any possible damage that may have occurred since the mat was laid, the following tests should be performed:

- Use a digital multi-meter to measure the resistance between the conductors of the mat/cable power leads again (see Section 7.7). If possible, an electrician should perform an insulation resistance test on the mat/cable. A megohmmeter adjusted to a minimum 1000 VDC should give a measured value at least 20 megohms (M $\wedge$ ).

#### Important

- Be prepared to install a marker plate or other identification indicating the presence of NeverFreeze® in the slab. This helps to alert anyone doing future work on the site of the presence of NeverFreeze® cable/mat to prevent inadvertent damage. Install a marker plate where clearly visible in each snow-melted area. A marker plate is placed flush in the soft asphalt surface. Other types of surfaces should be made to allow the marker plate to be installed flush with the surface. Take care to not damage the heating cable.
- Step 8: If required, apply a prime coat to the first course or untreated base over the top of the cable.

Use 1/2-inch aggregate or smaller. Larger aggregate can cut or pinch the cable. Before applying ensure the asphalt temperature is not greater than 285°F (140°C) or if directly into asphalt no greater than 220 F (105 C). Good compaction of the asphalt requires a certain temperature range at installation depending on the type of asphalt being installed. Manually lay the asphalt onto the area. Do not apply with asphalt machines as they may damage the cable. Spread the asphalt so that no less than 1-1/2 inches and no more than 3 inches covers the top of the heating cables. Compact the asphalt with any power roller as recommended. If possible, move the roller perpendicular with the cable direction to help avoid stress on the cable below.



\*Be careful not to stop or start the roller over the mats as this could cause the asphalt to shift, potentially damaging the cables.

## Important

Make sure the heating cable is fully embedded as well as 2 to 6 inches of the conduits enclosing the power lead and slab sensor wiring (if used).

DO NOT energize the NeverFreeze® system until the asphalt is fully cooled and cured according to the manufacturer's instructions.

- Step 9: Use a digital multimeter to measure the resistance between the conductors of the mat/ cable power leads again. Record these resistances in the Warranty Registration Form Reading 3 under AFTER COVERINGS ARE APPLIED. Please refer to Section 7.7.

### 7.12.3 Stone or Paver Application

- Step 1: Follow guidelines recommended by the paver manufacturer. If a layer of sand is to be applied over the gravel base, the mat/cable must first be secured in place and then covered with a minimum 1-1/2 inch layer of sand to completely embed the mat.
- Step 2: (NeverFreeze® Mat) Begin laying out the mat and secure it onto the base with landscape fabric stakes over the mat tape approximately every 2 feet. Make sure it is laid flat. Do not use metallic stakes or staples directly over the heating cable. Be careful not to damage the heating cable.

OR

- Step 2: (NeverFreeze® Cable) Secure plastic mounting cable ties to the gravel base, driving long nails through the head of the cable tie. Apply cable ties at the end of each run and at every 3 to 4 feet. Do not use metallic cable ties as they may damage the cable.

Lay out the cable and secure with the cable ties.

- Step 3: Use a digital multi-meter to measure the resistance between the conductors of the mat/cable power leads again. Record these resistances in the Warranty Registration Form AFTER MAT/CABLE IS SECURED IN PLACE. Please refer to Section 7.7.
- Step 4: Feed the power leads through the conduit into the junction box, leaving at least 6 inches of free lead length. Secure the heating cable and splice so that they will not be pulled into the conduit.

Insert a generous amount of electrical conduit sealant into the conduit end around the power leads to prevent water entry.

- Step 5: If a slab sensor is being installed, place the sensor socket according to the instructions. Secure and seal it to the conduit installed earlier. It should be located halfway between heating cables and in an area that is recommended by the sensor manufacturer. Make sure the top of the sensor will be flush with the surface of the finish layer. Make sure it is protected with a cap or seal.
- Step 6: Take a photo of the mat/cable installation. This can be very helpful later for utility work, changes to the site, etc. to avoid possible damage. Keep the photos with this installation manual.
- Step 7: Before beginning work, inspect the mat/cable for damage and secure any mat/cable that may have come loose.

To avoid burying any possible damage that may have occurred since the mat was laid, the following tests should be performed:

- Use a digital multi-meter to measure the resistance between the conductors of the mat/cable power leads again (see Step 7.7). If possible, an electrician should perform an insulation resistance test on the mat/cable. A megohmmeter adjusted to a minimum 1000 VDC should give a measured value at least 20 megohms (M $\wedge$ ).



## **Important**

Be prepared to install a marker plate or other identification indicating the presence of NeverFreeze® in the slab. This helps alert and avoid possible damage from future on-site. Install a marker plate where clearly visible in each snow-melted area. A marker plate is placed flush in the wet concrete surface or soft asphalt surface. Other types of surfaces should be made to allow the marker plate to be installed flush with the surface. Do not damage the heating cable.

- Step 8: Manually spread sand over the top of the cables and base so that no less than 1-1/2 inches covers the top of the heating cables. Be careful not to use sharp tools.

Compact the sand as recommended by the paver manufacturer, being careful not to uncover any of the NeverFreeze® mat/cable and not to damage the conduits coming into the slab area. Use hand compacting tools around the conduit area. Add more sand if necessary to maintain minimum 1-1/2 inches over all of the cables and conduit.

Place the pavers over the top and finish as required.

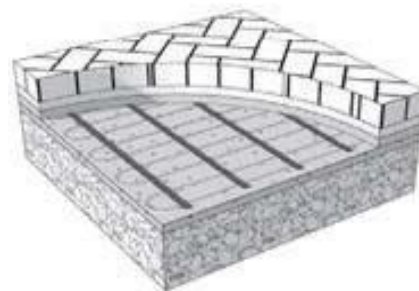

## **Important**

Make sure the heating cable is fully embedded as well as 2 to 6 inches of the conduits enclosing the power lead and slab sensor wiring (if used).

It is highly recommended that pavers be no more than 2-1/2 inches thick.

- Step 9: Use a digital multimeter to measure the resistance between the conductors of the mat/ cable power leads again. Record these resistances in the Warranty Registration Form AFTER COVERINGS ARE APPLIED. Please refer to Section 7.7.

### **7.12.4 Ceramic or Stone Tile Application**

- Step 1: NeverFreeze® mats or cables can be installed in the structural slab or in a thick mortar bed above a structural slab. In either case, the base material should be prepared according to section 7.12.1 Concrete Application.
- Step 2: (NeverFreeze® Mat) Begin laying out the mat and secure it onto the base with landscape fabric stakes over the mat tape approximately every 2 feet. Make sure it is laid flat. Do not use metallic stakes or staples directly over the heating cable. Be careful not to damage the heating cable.
- Step 2: (NeverFreeze® Cable) Secure plastic mounting cable ties to the gravel base, driving long nails through the head of the cable tie. Apply cable ties at the end of each run and at every 3 to 4 feet. Do not use metallic cable ties as they may damage the cable.

Lay out the cable and secure with the cable ties.

- Step 3: Use a digital multimeter to measure the resistance between the conductors of the mat/cable power leads again. Record these resistances in the Warranty Registration Form AFTER MAT/ CABLE IS SECURED IN PLACE. Please refer to Section 7.7.
- Step 4: Feed the power leads through the conduit into the junction box, leaving at least 6 inches of free lead length. Secure the heating cable and splice so that they will not be pulled into the conduit.

Insert a generous amount of electrical conduit sealant into the conduit end around the power leads to prevent water entry.

- Step 5: If a slab sensor is being installed, place the sensor socket according to the manufacturer's instructions.

Secure and seal it to the conduit installed earlier. It should be located halfway between heating cables and in an area that is recommended by the sensor manufacturer. Make sure the top of the sensor will be flush with the surface of the finish layer. Make sure it is protected with a cap or seal.

- Step 6: Take a photo of the mat/cable installation. This can be very helpful later for utility work, changes to the site, etc., to avoid possible damage. Keep the photos with this installation manual.
- Step 7: Before beginning work, inspect the mat/cable for damage and secure any mat/cable that may have come loose.



To avoid burying any possible damage that may have occurred since the mat was laid, the following tests must be performed:

- Use a digital multimeter to measure the resistance between the conductors of the mat/cable power leads again (Section 7.7). If possible, an electrician should perform an insulation resistance test on the mat/cable. A megohmmeter adjusted to a minimum 1000 VDC should give a measured value at least 20 megohms (M $\Omega$ ).

### **Important**

Be prepared to install a marker plate or other identification indicating the presence of NeverFreeze® in the slab. This helps to alert anyone doing future work on the site of the presence of NeverFreeze® cable/mat to prevent inadvertent damage. Install a marker plate where clearly visible in each snow-melted area. A marker plate is placed flush in the wet concrete surface or soft asphalt surface. Other types of surfaces should be made to allow the marker plate to be installed flush with the surface. Take care to not damage the heating cable.

Step 8: For either application below, exterior-grade materials should be selected and installed according to manufacturer's recommendations. Only vitreous tile (non-porous) should be used as other tile will absorb moisture which will lead to system failure. The maximum thickness above the cable should be no less than 1-1/2 in and no more than 2-1/2 inches. A movement joint should be installed between any heated and non-heated area.

### **Dry-set or Latex-Portland Cement (Thin-set Mortar Application)**

In this application, the mat or cable is already installed in the concrete slab. The primary concern is to install a cement mortar bond coat (thin-set) and tile according to Tile Council of North America (TCNA) recommendations for exterior applications (F102-07). Mortar and grout materials should be as specified per American National Standards Institute (ANSI) for exterior applications.

### **Cement Mortar or Thick-set Application**

In this application, the mat or cable is installed above the structural slab in a thick mortar bed and bond coat according to TCNA F101.07. A 1-1/4 inch minimum mortar bed should be placed over the cable or mat according to ANSI A108.1A guidelines. Above this layer, the mortar bond coat and tile is installed.

- Step 9: Use a digital multimeter to measure the resistance between the conductors of the mat/ cable power leads again. Record these resistances in the Test Log Sheet AFTER COVERINGS ARE APPLIED. Please refer to Section 7.7.

## **7.13 Controls and Sensors Installation**

- De-energize all circuits feeding this system before doing any electrical work.
- If a slab sensor is being installed, uncover the cap or seal on the embedded sensor socket. Feed the sensor leads through the conduit up to the control. Secure the sensor into the socket and finish this installation as recommended by the sensor manufacturer.
- Make wire connections at junction boxes for the NeverFreeze® mat/cable power leads to the power wiring from the control. If the junction box is located outdoors, it is highly recommended to use wet-location-rated wire nuts or crimps to avoid corrosion.
- Install the control at its location according to the instructions provided with the control. Make wiring connections to the power source and to the sensor wires and mat/cable lead wires.
- Proceed to test the GFEP relay (ground fault protection) using the test button, then reset it. If the circuit does not disengage, or does not re-engage, then check its protection level and setting level. Make some adjustment and re-test or troubleshoot to fix it.

## Important

The ground wire supplied with the mat/cable must be connected to a suitable grounding/earthing terminal.

After careful inspection of all wiring, connect the power supply wiring to the breaker and turn it on. If your control panel does not include GFEP protection, the circuit breaker should have it.

Follow instructions for the control to set it up. The sensor should not allow the system to energize the NeverFreeze® until proper conditions exist. The control may allow you to temporarily test the system for just a few minutes. If you have a clamp-on-type electrical test meter, energize the system briefly and verify it is drawing the proper level of current into the mat/cable as planned. Then turn the system off.

## Important

Do not fully energize the NeverFreeze®, except for this brief test, until the concrete is cured or asphalt is cool. This could cause improper curing of the surface materials.

CAUTION: Do not operate the system with air temperatures above 50°F (10°C) except for this brief test. This will stress the materials and reduce the life of the heating cable and may cause damage to the materials and heating cables.

## 8. Commissioning

### Important

For the extended limited warranty to apply, you must perform these tests, record the results on the test log sheet and send the original sheet to ThermoSoft®. Retain a copy for your records.

#### 8.1 Insulation Resistance Test with a Megohmmeter

This test ensures that the insulating jackets of the cable are not damaged. A low value indicates the cable has been damaged and must be replaced. A megohmmeter adjusted to a minimum 1000 VDC should give a measured value at least 20 megohms (M $\Omega$ ).

#### WARNING

Megohmmeter applies high voltage and could shock or cause serious injury or death if improperly used. Follow megohmmeter instructions for safe and proper use.

- Connect the ground wire to the black lead and both power wires to the red lead of the megohmmeter.
- Adjust the megohmmeter to a minimum 500 VDC. Repeat the test at 1000 VDC.
- Make sure the megohmmeter reads at least 20 megohms (M $\Omega$ ). If you get a lower reading, contact ThermoSoft®.
- Record your readings on the Test Log Sheet.



#### 8.2 Insulation Resistance Test with a Digital Multimeter

This test ensures that the insulating jackets of the cable are not damaged. A low value indicates the cable has been damaged and must be replaced.

- Set your multimeter to the 20 M ohms range.
- Connect the ground wire to the black lead and both power wires to the red lead of the multimeter.
- Make sure the meter reads “Open” or “OL” or “I” depending on your meter (default reading indicated for an open circuit). If you get a different reading, contact ThermoSoft®.
- Record these readings on the Test Log Sheet.

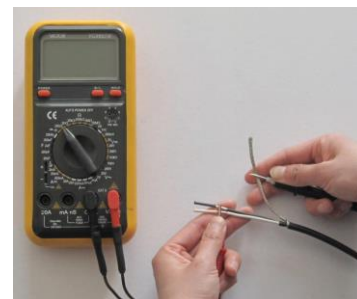

### 8.3 Heating Cable Resistance Test

This test measures the resistance of the NeverFreeze® Cable and is used to determine circuit integrity.

- Set your multimeter to the 200 or 2000 ohms range.
- Connect the multimeter leads to the black and white power wires.
- Compare this resistance reading to the resistance value specified in the Product Selection Table 1 (Imperial ) or Table 2 (Metric Measurements). The value should be within  $\pm 10\%$ . If you get a different reading, contact ThermoSoft®.
- Record these readings on the Test Log Sheet.

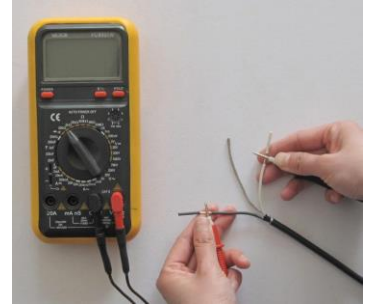

**Once completed, please send the Test Log Sheet to ThermoSoft® to validate your warranty.**

### **9. Start-up & operation**

Once the installation is ready and the tests completed, and when temperature and humidity/precipitation allow (below 4C/38F) you may start the system. Each installation is different and settings should be optimized with the available control adjustments.

You may increase or decrease the temperature set-point, the hold-on timer or after run timer according to the installation conditions for optimal operations during the first winter and once a season, depending on the weather conditions.

Each winter, certain combination of temperature and precipitation may generate rapid ice build-ups. Bridge-building on top of the snow sensors may temporarily create an igloo effect with an ice cap, thus preventing start-up signal which is normal. So, when it happens, you must clean the snow sensors to get rid of such ice cap. Otherwise, the system may not be able to start a snow melting cycle for many days. Clean regularly pavement sensors which may get clogged with dirt/ sand, which will prevent false call signals.

## 10. Troubleshooting

If you are not qualified to perform electrical installations, it is strongly recommended that a qualified licensed electrician be hired to install and connect the heating cables and related electrical controls and components. If problems with the system should arise, please consult the troubleshooting guide below. Any troubleshooting work should be done with the power removed from the circuit unless otherwise indicated. Call ThermoSoft® for further assistance.

Problem	Possible Cause	Solution
Mat/cable resistance measurement is outside the range printed on the nameplate label.	An analog ohmmeter (using a moving needle) was used to take the reading.	Obtain a digital ohmmeter (multimeter) able to read 0 to 20,000 ohms (Ω) and remeasure the resistance.
	If measurement shows an open or short circuit, the heating cable has been damaged.	Record resistances between all power lead wires and contact ThermoSoft®.
	If measurement is only slightly low or high, air temperature has affected the resistance.	Place the mat/cable in a room 65 to 75°F and remeasure after 1 hour.
	The resistance measurement could be from more than one mat/cable.	Disconnect all cables/mats from each other and from controls and remeasure the resistance of each cable.
	The ohmmeter (multimeter) is set to the wrong scale.	If the ohmmeter (multi-meter) has multiple ranges (e.g., 200Ω, 2kΩ, 20kΩ, 200kΩ, 20MΩ) set the range to 200 Ω and remeasure.
Snow / ice is not melting.	Mat/cable has been damaged.	Measure mat/cable resistances between all power lead wires as shown in Section 7.7 of this manual. If the resistance measurement indicates an open or short-circuit, record these resistances and contact ThermoSoft®.
	GFEP has tripped.	Try resetting the GFEP on the circuit breaker ONCE. If it trips again, do not continue to try resetting it. Check for loose wire connections in the breaker panel, junction boxes, controls, etc. Measure mat/cable resistances between all power lead wires as shown in Section 7.7. If the resistance measurement indicates an open or short-circuit, record these resistances and contact ThermoSoft®.
	Incorrect voltage applied.	Briefly energize the system and use a multimeter to measure the voltage between power lead wires of the mat/cable. Check voltage ratings for each control and cable to make sure they match. If possible, use a digital multimeter to measure the current into each mat/cable.
	Mats/cables are connected in series.	Multiple mats/cables must be connected in "parallel."
System operates continuously.	Incorrect wiring. Control was "bypassed."	Check wire connections. See control manufacturer's wire instructions and wire instructions in this manual.
	Faulty control. Relay is not opening properly.	Check the control manufacturer's instructions.

## 11. Extended warranty

For information on ThermoSoft's NeverFreeze Snow Melting warranty, see additional Warranty Sheet.

<b>WARRANTY CERTIFICATE</b>			
<b>Snow Melting Cables and Mats</b>			
Please complete this installation completion certificate and retain a copy with photos to validate the warranty.			
Owners Name:			
Address:			
Area(s) Installed:			
Product SKU#(s)			
Resistance (Ohms) Out of Box:			
Resistance (Ohms) After Installation:			
Resistance (Ohms) Before Pouring Sand/Concrete/Asphalt:			
Resistance (Ohms) After Surface Material Application:			
Resistance (Ohms) Before Energizing Cables for First Time:			
Remember to measure the resistance between two resistance conductors as well as the resistance between each conductor and the ground wire.			
ThermoSoft recommends using a megohmmeter to test the insulation resistance.			
Installer's Name:	Phone:		
Electrician's Name:	Phone:		
Electrician's License Number:			
Signed by electrician:			
Date Completion Tested:			